

Specification

770137(200120HF) Insulated Holding Cabinet



- ◆ Designed for holding.
- ◆ Digital Electronic Controls, select a Variety of holding temperatures.
- ◆ temperature even deasign without fan to keep food fresh & moisture.
- ◆ Control features indicator indicator for the hold function.
- ◆ Side racks with fifiteen pan positions spaced on 1-1/2”(38mm)centers,per compartment.
- ◆ solid door with magnetic door latch,Zinc Alloy Machined handle.
- ◆ Heavy duty 5”casters,two swivel with brakes, two Rigid.Provides mobility when fully loaded.
- ◆ temperature range 70F~200F.
- ◆ Made of stainless steel.



Note: Dimensions and Specification are subject to change without notice.

This Energy Efficient Full size cabinet has two individual, dual controlled, featuring a uniform heat source that maintains close temperature tolerances throughout the holding function. As a result, consistent holding offers low shrinkage of bulk or portion-cut protein items, higher food moisture content and significantly longer holding life. Max temperature 200F.

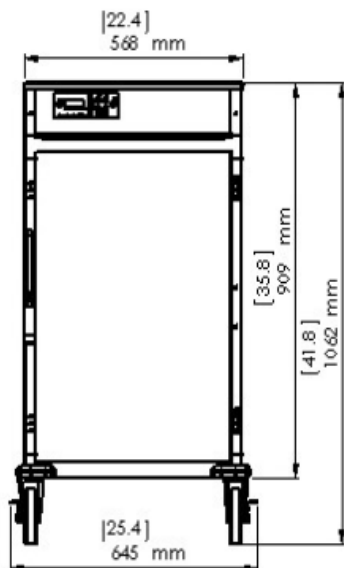
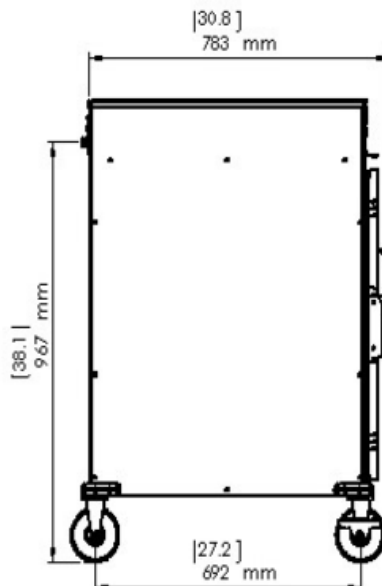
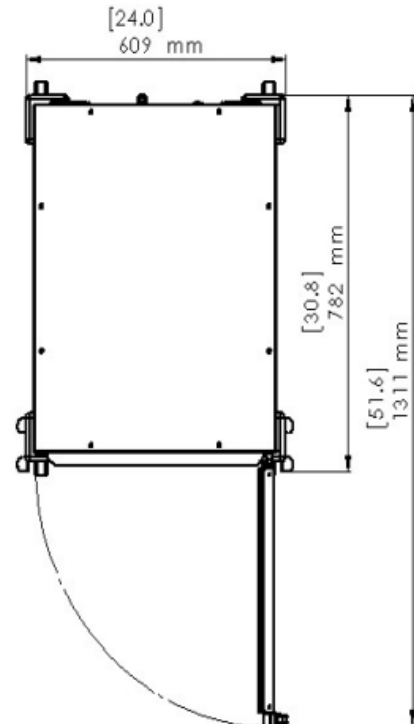
770137(200120HF) Insulated Holding Cabinet
Front View

Side View

Top View

Pan Capacity	18" x 26" x1	15 PCS.
	20" x 12" x2-1/2	8PCS
	20"x12"x4	4 PCS.
	20" x12" x6	4 PCS
Electrical	120 Volts,7.5Amps,60Hz	
Power	900 Watts	
Cord MEMA	5-15P plug	
Net weight	196 lbs(89KG)	
Gross shipping weight	218 lbs(99KG)	
Class	100	
Dimensions	25.4" W x 31"D x 41.75" H	
Package	26" W x 33"D x42" H	
Warranty	1 year manufactures limited Warranty	