

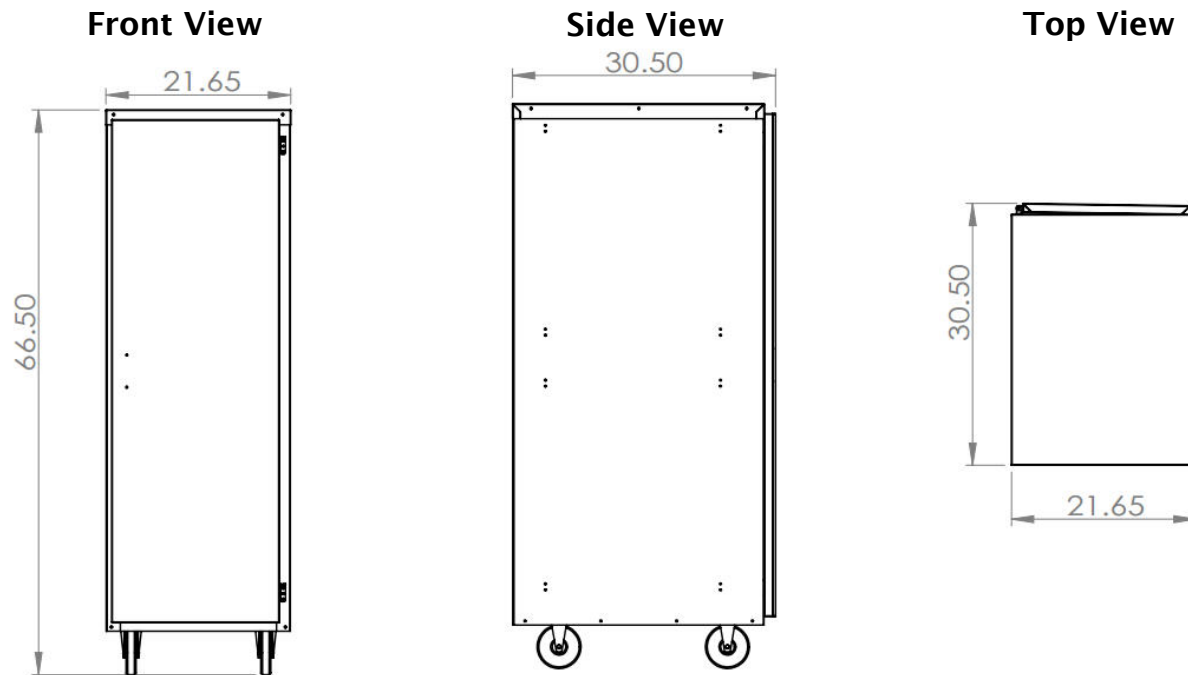

- ◆ Enclosed mobile transportation cabinet.
- ◆ Magnetic closed door.
- ◆ Total pan capacity is thirty seven full size pan (18"x26")
- ◆ High quality 5" casters, two with safety-lock.
- ◆ Non-insulated.
- ◆ Galvanized aluminum.
- ◆ Sanitary and rustproof.
- ◆ Prevents dehydration.
- ◆ It ships knocked down & is easy to assemble.

Note: Dimensions and Specification are subject to change without notice.

This full-size Non insulated Mobile Transportation cabinet can hold up to thirty seven 18" x 26" full size pans, as well as a variety of others. Offering the ability to transport and store a variety of plate sizes. Designed with enduring quality in mind.



Model Number 770087(MT1)

Electrical Not applicable

Power Not applicable

Net Weight 143lb/65KG

Gross shipping weight 156.5lb/71KG

Class 100

Dimensions 21.65"WX30.5"D \times 66.5"H

Package 29.9"WX62.2"D \times 10"H