

Specification

Pass Through

771017(HFWDF9L)Insulated Heater Proofer



- ◆ Designed for proofing and heating.
- ◆ All digital display and controls.
- ◆ Machined Zinc Alloy handle
- ◆ Adjustable thermostat for a variety of warming temperatures.
- ◆ Holding temperature up to 185 F.
- ◆ Water pan provides moisture for proofing
- ◆ Multipurpose universal rack system
- ◆ Humidity up to 95%(under 90F)
 - ◆ Clear polycarbonate door for viewing.
- ◆ High quality 5" casters,two with safety-lock.
- ◆ Aluminum cabinet



Note: Dimensions and Specification are subject to change without notice.

This full-size Insulated Cabinet offers this wider cabinet features a 6" revolutionary rack system, offers 3" spacing. Eight 24"x24" pans, Sixteen 20"X12" or Eight 18"x26" pans. Made for 18", 20", 22" and 24"pizza boxes.Offering the ability to proof a variety of backed goods,allowing dough to rise before backing.All digital temperature controls with easy set up.Enables a variety of temperatures,including warming.Designed with enduring quality in mind.



Specification

771017(HFWDF9L) Insulated Heater Proofer

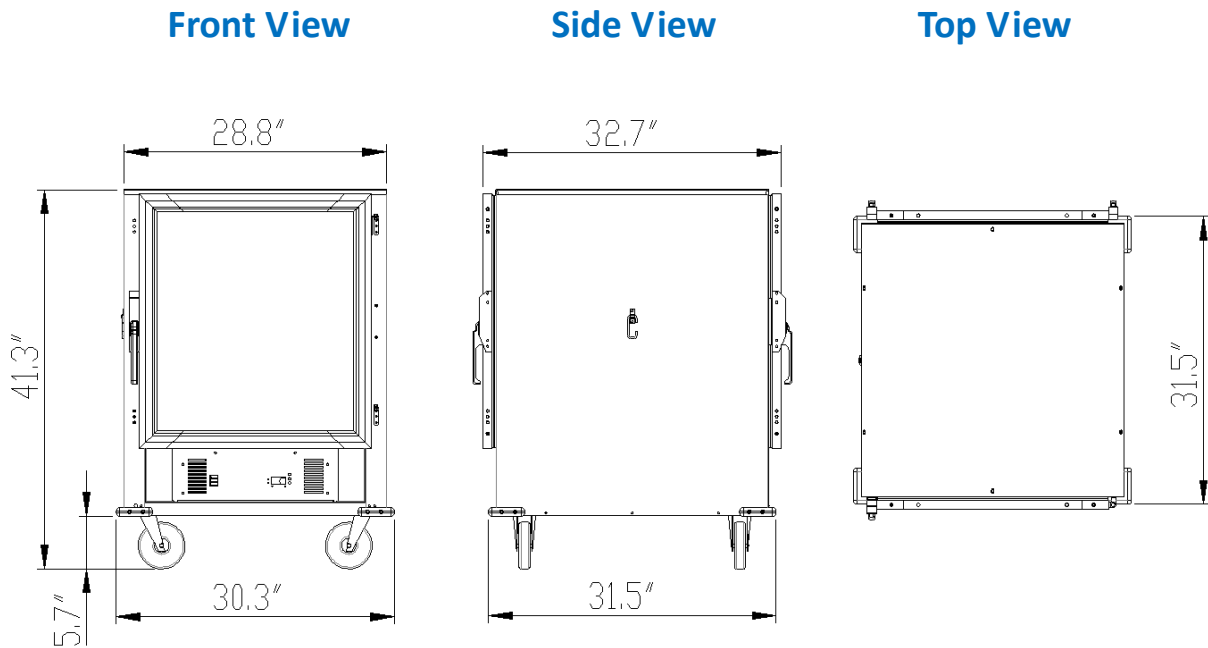

Pan Capacity	Multipurpose Universal rack system 6" shelf/ storey, 3" spacing, Eight 24"x24" pans, Sixteen 20"x12". Or Eight 18"X26" pans 18", 20", 22" and 24"pizza boxes. Hold steam pans as well
Electrical	120 Volts
Power	1500 Watts
Net weight	204 lbs/92kg
Gross shipping weight	246 lbs/76kg
Class	100
Dimensions	30.4" W x 34"D x 41.3" H
Package	31" W x 35"D x 42" H
Warranty	1 year manufactures limited Warranty