

## Specification

### 770087(UCS1)Non-Insulated Heater Proofer



- ◆ Designed for proofing and heating.
- ◆ All digital display and controls.
- ◆ Machined Zinc Alloy handle
- ◆ Adjustable thermostat for a variety of warming temperatures.
- ◆ Holding temperature up to 185F.
- ◆ Water pan provides moisture for proofing
- ◆ Humidity up to 95%(under 90F)
- ◆ Adjustable & Universal Rack System.  
Pan capacity is 9 stories 18" x 26".
- ◆ Clear polycarbonate door for easy viewing.
- ◆ High quality 5" casters,two with safety-lock
- ◆ Aluminum cabinet.



**Note: Dimensions and Specification are subject to change without notice.**

This 31" under counter heater proofer, is energy efficient, space savings, ADA cabinet, ideal when space is a concern. Featuring a universal and adjustable pan rack before baking. All digital temperature controls with easy set up. Enables a variety of temperatures, including warming. Designed with enduring quality in mind.

## Specifications

### 770087(UCS1)Non-Insulated Heater Proofer

**Front View**

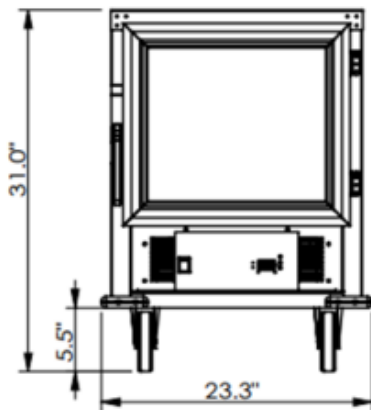

**Side View**

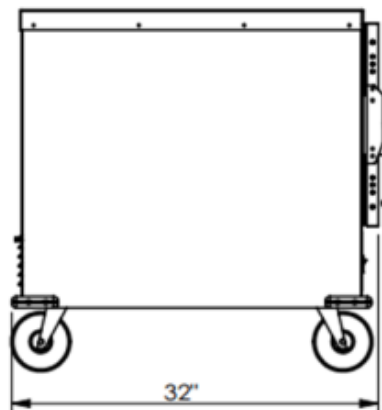

**Top View**

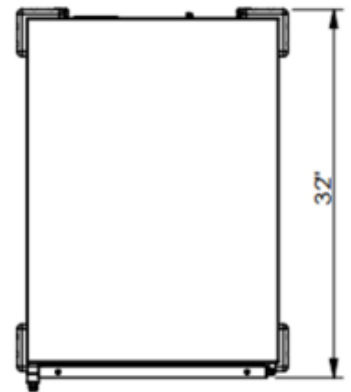

Pan Capacity	9 stories, 18" x 26" in 1-1/2".
Electrical	120 Volts
Power	1500 Watts
Net weight	94lbs
Gross shipping weight	104lbs
Class	100
Dimensions	23.3" W x 32"D x 31" H
Package	24" W x 33"D x 32 H
Warranty	1 year manufactures limited Warranty