



Specification

Countertop Food Warmer

550052(1B)



- Waterless design allow your convenient & safety Operation.
- No need water pan & water.
- Reduce operation & maintenance cost,unlike Traditional dry wells or steam table with water
- Stainless Steel Construction.
- Easy to clean.
- 6” deep open waterless pan.
- Individually controlled heating elements.
- Thermostatic heat controls and indicator lights.
- Limited manufacturers warranty .



Note:Dimensions and Specification are subject to change without notice

Specification

Countertop Food Warmer

550052(1B)

Side View

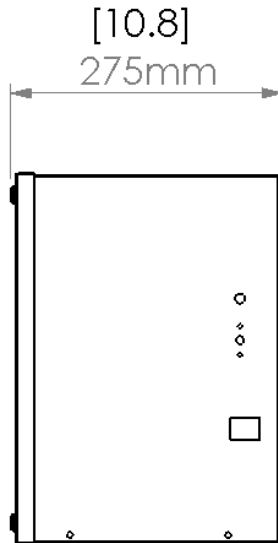

Top View

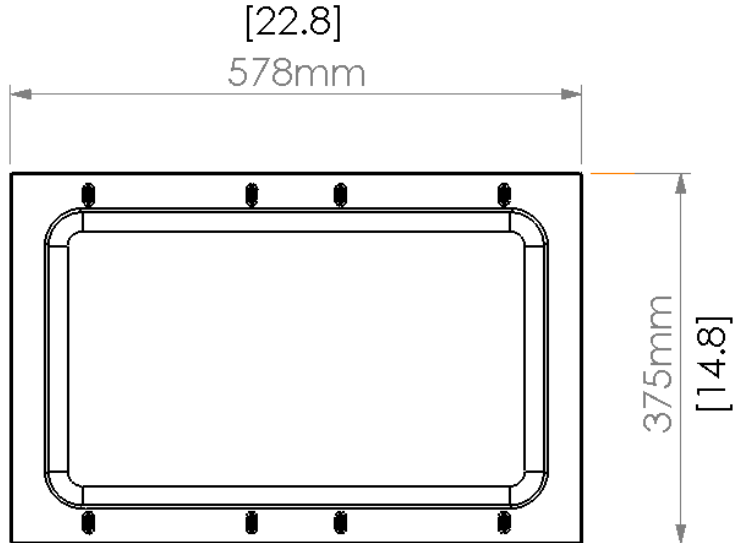

Pan Capacity 12" x 20" x 6"
Electrical 120 Volts, 4 Amps, 60Hz
Power 450 Watts

Net Weight 36.3 lbs (16.5 Kg)
Gross shipping weight 39 lbs (17.5 Kg)
Class 85

Dimensions 22.8" W x 14.8" D x 10.8" H
Package 26" W x 17.3" D x 22.6"

Warranty 1 Year Manufactures limited Warranty