

# Specification

## 550023

### Warmer Merchandiser



- ◆ Easy to clean.
- ◆ Aluminum cabinet.
- ◆ Tempered glass side and door panels.
- ◆ Designed for holding precooked specialty foods.
- ◆ Two clear glass doors front or rear counter applications.
- ◆ Adjustable chrome-plated racks can be placed flat or sloped.
- ◆ Adjustable thermostat, 450-watt element, Temperature up to 160°F.

2-Door warmer merchandiser is designed for counter applications. The operator side has controls and a door for easy loading. The consumer side has a door for self-serve. Features an adjustable thermostat with a circulating fan, three adjustable chrome-plated racks can that be placed flat or sloped and are removable for easy cleaning. Stainless Steel and Aluminum construction provides durability and ease of cleaning.

Front View

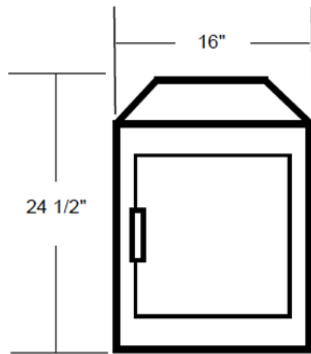

Side View

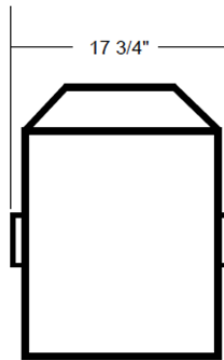

Top View

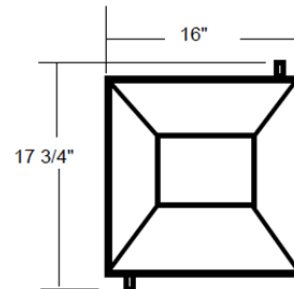

**Options** None

**Electrical** 120 Volts, 60 Hz

**Power** 450 Watts

**Net Weight** 39 lbs.

**Gross shipping weight** 42 lbs.

**Class** 85

**Dimensions** 16" W x 17.75" D x 24.5" H

**Package** 17.75" W x 19.75" D x 25" H

**Warranty** 1 Year Manufactures limited Warranty